



Pump Jack Fall Arrest System User Guide

PLEASE READ BEFORE INSTALLING WORKSAFE PUMP JACK SYSTEM: Failure to follow manufacturer's instructions could result in serious injury or death. The Guardrail Carriage #470625 must be used with the WorkSafe Pump Jack System.

Each part of the system must be installed and used properly to provide a safe working environment. Inspect each piece of the system prior to each use. **If any piece is bent, cracked or damaged discontinue use immediately.**

This also applies to any pump jack system used with our products.

System Use Instructions

Step 1 Before erecting your pump jack poles, place one WorkSafe Pump Jack Bracket (#470675) onto a pump jack pole and slide it into place so that it sits on top of the pump jack or the work bench.

Be sure that the interior roller of the WorkSafe Pump Jack Bracket (#470675) is facing the pump jack pole, and that the guardrail pockets on the WorkSafe Pump Jack Bracket (#470675) are facing towards the work surface.

Repeat this step with the second WorkSafe Pump Jack Bracket (#470675) and pump jack pole.

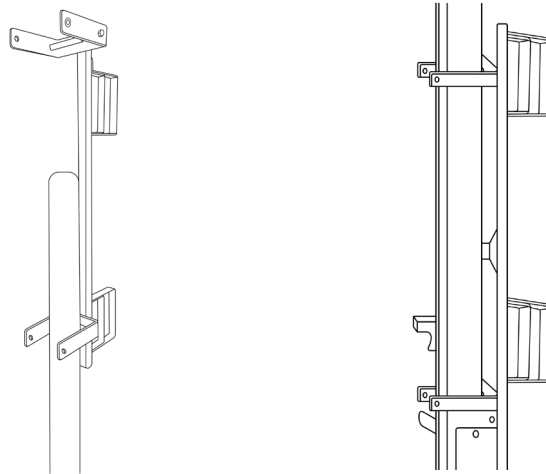

Step 2 Assemble the three (3) 7ft sections of the WorkSafe Aluminum Guardrail (#470645-E) by connecting the center beam to both end beams.

Once these are connected, affix eight (8) 5/16 flat head screws that came with your system on each side of the WorkSafe Aluminum Guardrail (#470645-E). Please note that **these screws are specifically made for this system, and using other 5/16 screws is not recommended.**

Once assembled, the WorkSafe Aluminum Guardrail (#470645-E) will be 21ft wide.

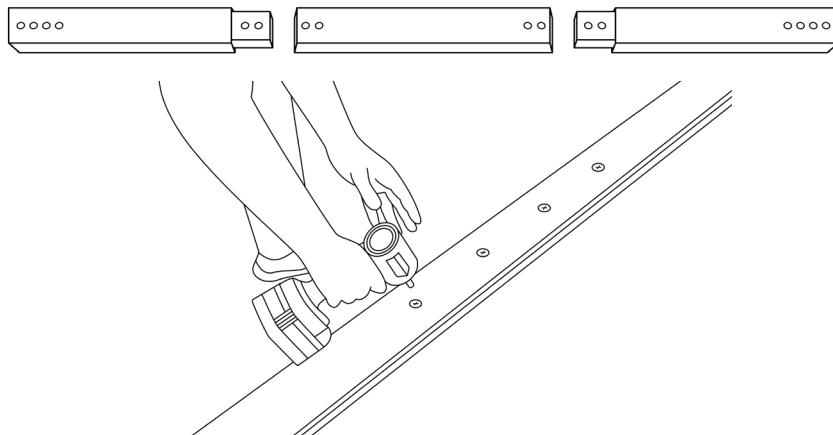

Step 3 Slide one side of your newly-assembled WorkSafe Aluminum Guardrail (#470645-E) into the upper rung of the WorkSafe Pump Jack Bracket (#470675).

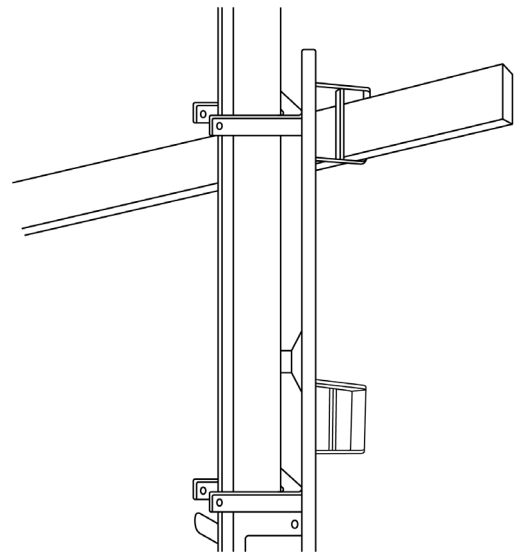

Step 4 Once one side of the WorkSafe Aluminum Guardrail (#470645-E) is through, slide the WorkSafe Guardrail Carriage (#470625) onto the WorkSafe Aluminum Guardrail (#470645-E) with O-Ring facing down. Once the carriage is on the guardrail, slide the other end of the guardrail through the other top pump jack bracket rung.

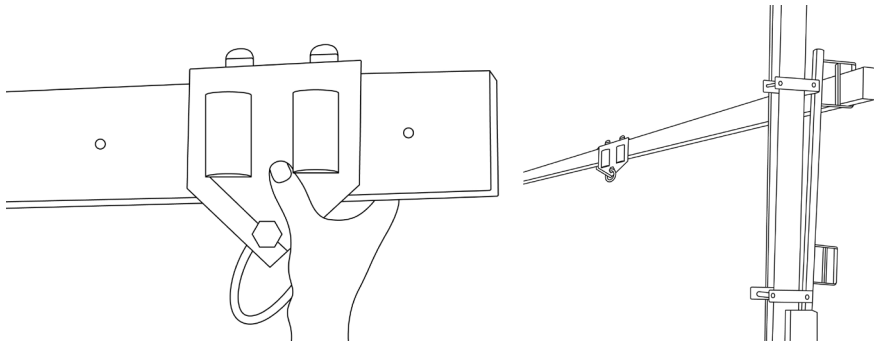

Step 5 Always center Guardrail between poles. To distribute weight evenly, never extend Guardrails to one side or the other. This could cause an unsafe force on rail causing rail to tip.

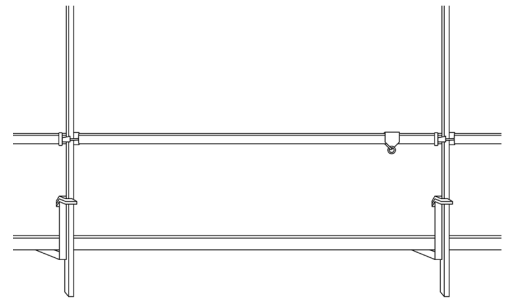

Step 6 Once you have adjusted the pump jack system to working height, connect the WorkSafe Self Retracting Lifeline (SRL) (#470670) to the WorkSafe Guardrail Carriage (#470625) and your harness.

Note: Only use a 6-foot-long ANSI approved SRL (Self Retractable Lifeline) with WorkSafe Carriage.

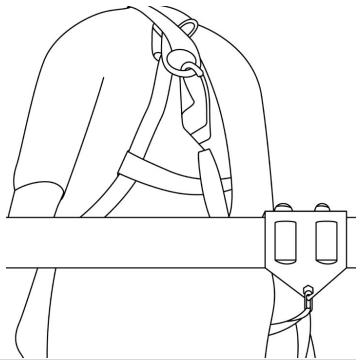

Step 7 Install adjustable WorkSafe Telescoping End Stops (#4706300) to each end of the Guardrail. Adjust End Stops to length and depth of work surface. Locate and install end stop pins on Guardrail nearest to each outer pole rail.

Note: Always position End Stop Pins to the OUTSIDE of each Guardrail Bracket to ensure the most secure setup.

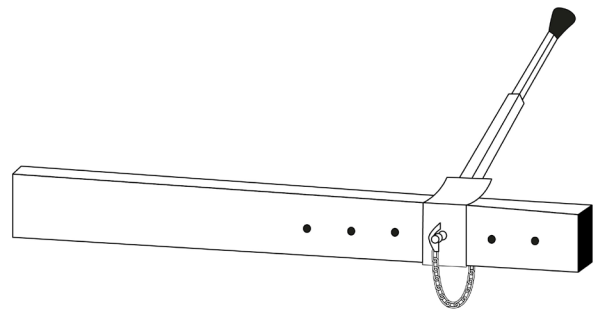

Adjustments / Alternate Uses:

If more than one person will be on the pump jack at any time, a second 21ft WorkSafe Aluminum Guardrail (#470645-E) with a WorkSafe Guardrail Carriage (#470625), and WorkSafe Self Retracting Lifeline (SRL) (#470670) are required.

Note: NEVER attach two WorkSafe Guardrail Carriages (#470625) to the same 21ft WorkSafe Aluminum Guardrail (#470645-E).

